



New Hampshire Ball Bearings, Inc.

A Minebea Company

# Long-Life Self-Lubricating Spherical Bearings

-3 thru -5A	.010 .005
-6 thru -24	.017 .010

.015  
.005 x 45° CHAMFER  
(TYP.)

CHAMFER TYPE

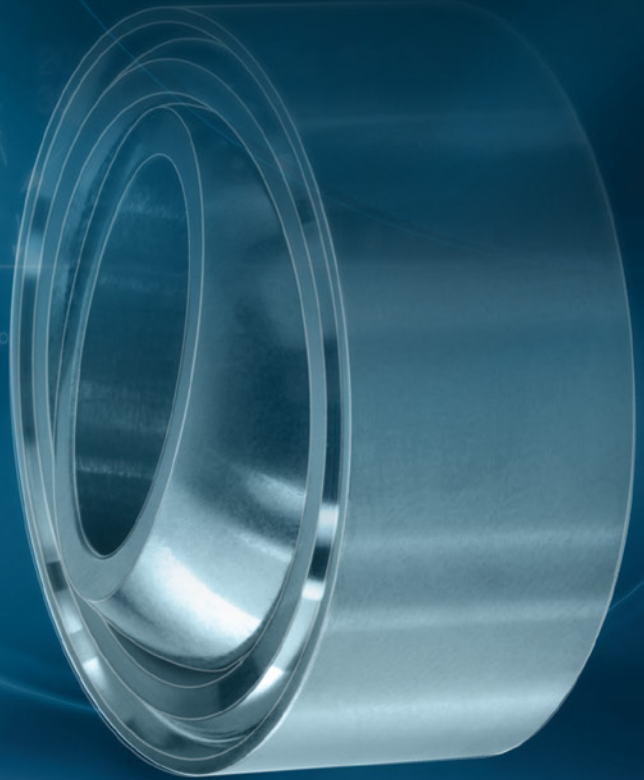

ASTRO DIVISION

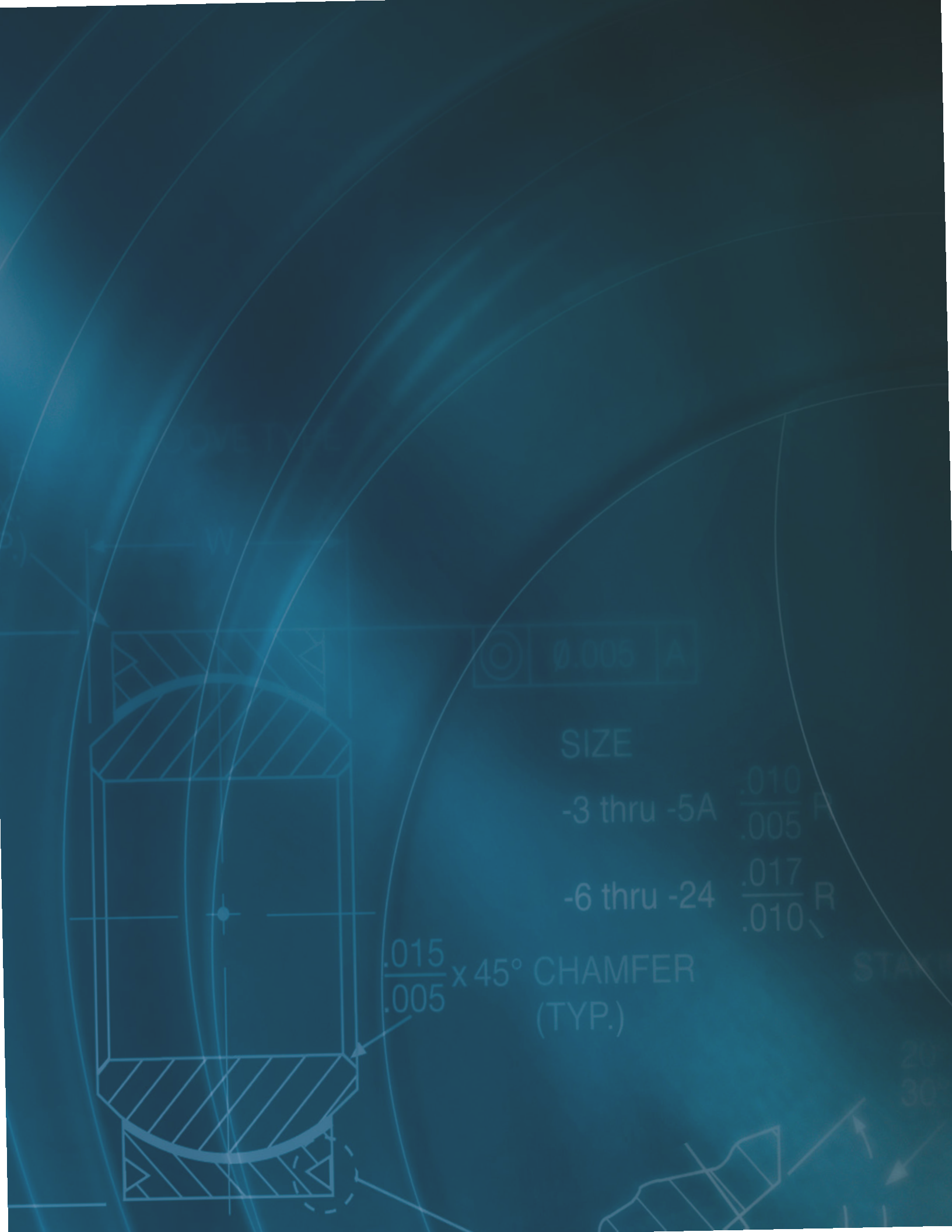

⊙  $\varnothing$ .005 A

SIZE

-3 thru -5A	$\frac{.010}{.005}$	F
-6 thru -24	$\frac{.017}{.010}$	R

$\frac{.015}{.005}$  x 45° CHAMFER (TYP.)

STAY

20  
30



# Long-Life Self-Lubricating Spherical Bearings Featuring NHBB's MK Liner System

*Introducing the industry's first self-lubricating liner system to qualify to the new performance threshold of 100,000 cycles for spherical bearing life, established by industry standard AS81820 Type A.*

NHBB's MK liner system utilizes PTFE to provide the long life and wear resistant surface required of Type A spherical bearings. Spherical bearings with the MK liner system offer the performance advantage of extended life at high loads in demanding aerospace applications such as flight controls, wing surface controls, actuators, landing gear, engine pylons, and engine mounts.

## Increased Design Flexibility and Longer Lasting Performance

Self-lubricating spherical bearings with the MK liner system:

- Are interchangeable with existing products
- Are qualified to the same wear limits as non Type A bearings, but at four times the bearing life
- Uniquely meet both the new AS81820 Type A standard and the non Type A standard.



## Engineering Support

For NHBB, the MK liner represents our ability to meet customers' exacting specifications and anticipate their needs. While we are well positioned to provide the industry's first series of long-life self-lubricating spherical bearings, we are dedicated to supporting our customers through the design and production of custom bearings, next-up assemblies, and machined parts. Please contact Astro's sales or engineering teams for assistance with your specific requirements.

## Interactive Site Visits

Need us to take a closer look? NHBB's Product Engineering team regularly travels to our customers' facilities to provide direct support in developing engineered solutions for any challenge. For more information, please contact NHBB's Product Engineering team at the Astro Division. 603.524.0004. email: info@nhbb.com.

**AS81820 TYPE A Dynamic Oscillation Wear Test Results**  
**NHBB's MS14103A Bearings—MKW5V, MKW8V, and MKW12V**

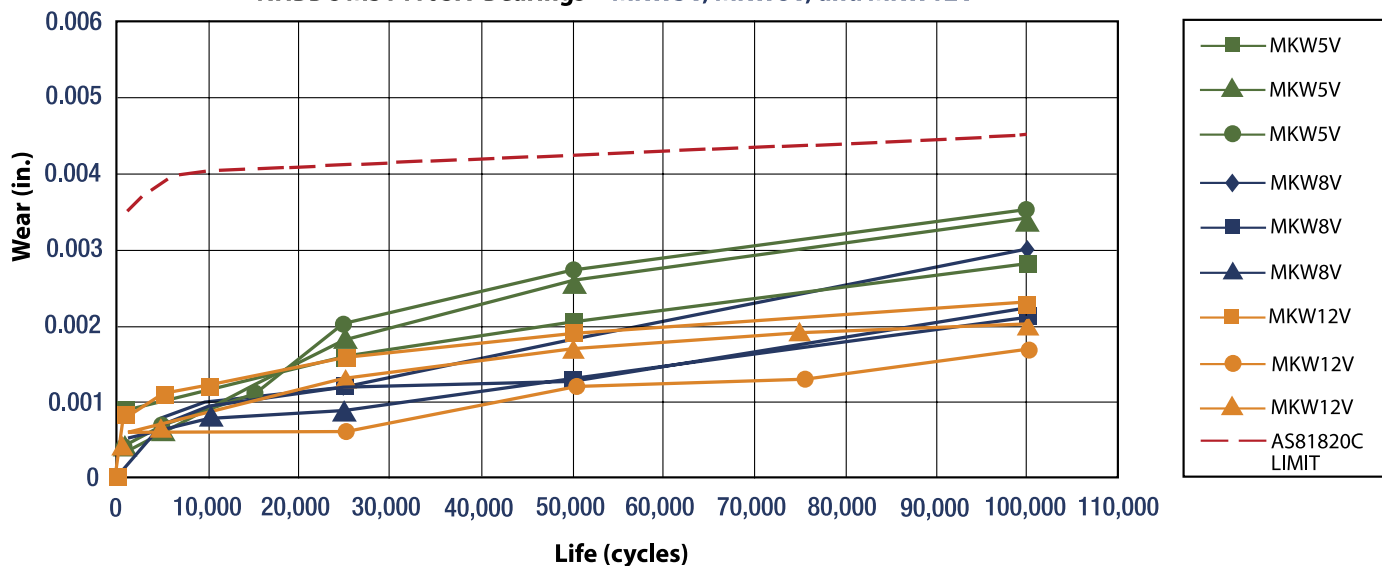

BEARING P/N	TEST LOAD (LBS.)
MKW5V	6,050
MKW8V	14,950
MKW12V	26,200

**Test Parameters:**

1. Conditions: Room temperature, dry
2. Oscillation angle: +/- 25°
3. Frequency: 20-30 cycles per minute

NHBB also holds qualification to the AS81820 Type A lined bore series - M81820/1A, M81820/2A, and M81820/4A.



AS81820 Type A

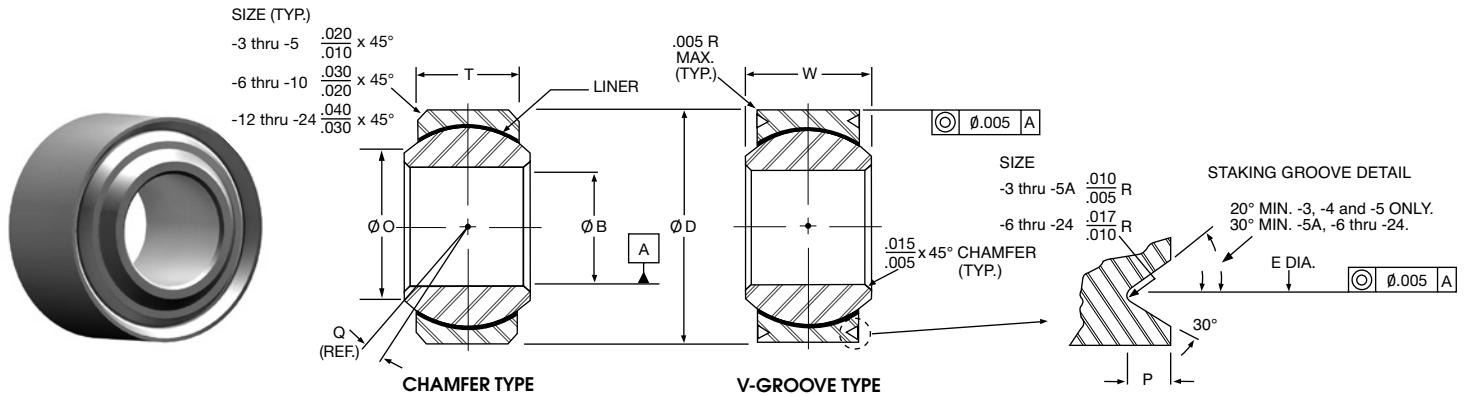

Narrow Series

PART NUMBER V-GROOVED*	MS DASH NO.	(B) BORE DIA.	(D) OUTSIDE DIA.	(W) BALL WIDTH	(T) RACE WIDTH	(O) SHOULDER DIA.	BALL DIA.	(E) PITCH DIA.	(P) GROOVE DEPTH	(Q) MIS-ALIGNMENT DEGREE	LIMIT STATIC RADIAL LOAD LBS.	LIMIT STATIC AXIAL LOAD LBS.	DYNAMIC OSC. RADIAL LOAD LBS.	WEIGHT LBS.
MS14101A MS14104A		+0.000 -0.0005	+0.000 -0.0005	+0.00 -0.002	±.005	MIN.	REF.	+0.00 -0.008	+0.00 -0.010	REF.				REF.
MKB3V	-3	.1900	.5625	.281	.218	.293	.437	.500	.025	10°	3,975	150	1,500	.020
MKB4V	-4	.2500	.6562	.343	.250	.364	.531	.594	.025	10°	6,040	430	3,320	.020
MKB5V	-5	.3125	.7500	.375	.281	.419	.562	.650	.035	10°	8,750	700	5,460	.030
MKB5VA	-5A	.3125	.7500	.375	.281	.419	.562	.660	.035	10°	8,750	700	5,460	.030
MKB6V	-6	.3750	.8125	.406	.312	.475	.656	.712	.035	9°	10,540	1,100	6,600	.040
MKB7V	-7	.4375	.9062	.437	.343	.530	.718	.806	.035	8°	13,200	1,400	8,050	.050
MKB8V	-8	.5000	1.0000	.500	.390	.600	.813	.876	.055	8°	17,900	2,100	10,400	.070
MKB9V	-9	.5625	1.0937	.562	.437	.670	.875	.970	.055	8°	23,200	3,680	13,000	.090
MKB10V	-10	.6250	1.1875	.625	.500	.739	.968	1.063	.055	8°	30,500	4,720	16,450	.120
MKB12V	-12	.7500	1.4375	.750	.593	.920	1.187	1.313	.055	8°	46,400	6,750	23,600	.210
MKB14V	-14	.8750	1.5625	.875	.703	.980	1.312	1.438	.055	8°	62,200	9,350	30,250	.270
MKB16V	-16	1.0000	1.7500	1.000	.797	1.118	1.500	1.626	.055	9°	82,200	12,160	38,000	.390
MKB18V	---	1.1250	2.1250	1.125	.900	1.334	1.750	2.003	.055	8°	105,880	13,500	42,350	.720
MKB20V	---	1.2500	2.3125	1.250	1.000	1.473	1.937	2.190	.055	8°	131,230	16,930	52,490	.930
MKB22V	---	1.3750	2.5625	1.375	1.100	1.654	2.156	2.440	.055	8°	161,700	20,750	64,680	1.280
MKB24V	---	1.5000	2.8125	1.500	1.200	1.794	2.344	2.690	.055	8°	191,973	24,950	77,110	1.670

\*For chamfered version, delete 'V' from part number.

◆ MKB5VA is a V-groove type bearing only.

Notes:

- Bearing sizes -3 through -16 are approved for procurement to AS81820 Type A and Aerospace Standards AS14101 through AS14104.
- Bearing sizes -18 through -24 are not included in current Aerospace Standards, but are offered as NHBB catalog items only.
- Operating temperature range per AS81820 Type A is -65 to +325 °F. Broader temperature capabilities are achievable.
- All dimensions are in inches unless otherwise specified.

MATERIALS			
Part No.	Ball	Race	Liner
Catalog No.	CRES 440C	CRES 17-4PH	PTFE/Fabric
	AMS 5630	AMS 5643	Bonded to Race I.D.
	55-62 HRC	28-37 HRC	No Lub. Required
Catalog No.	CRES PH13-8Mo	CRES 17-4PH	PTFE/Fabric
+ 13-8	AMS 5629	AMS 5643	Bonded to Race I.D.
	43-47 HRC	28-37 HRC	No Lub. Required





AS81820 Type A

Aerospace Standard P/N

MS14101X – X X X X X

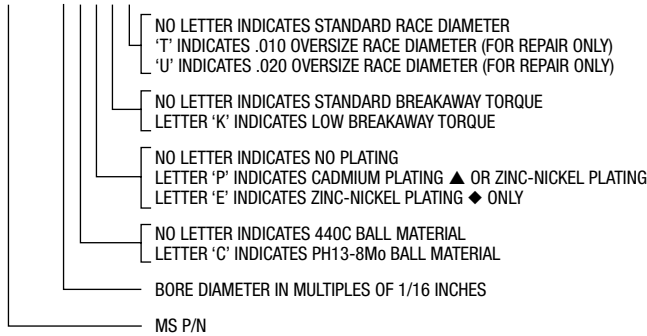

NHBB P/N

MK X X V X X X X

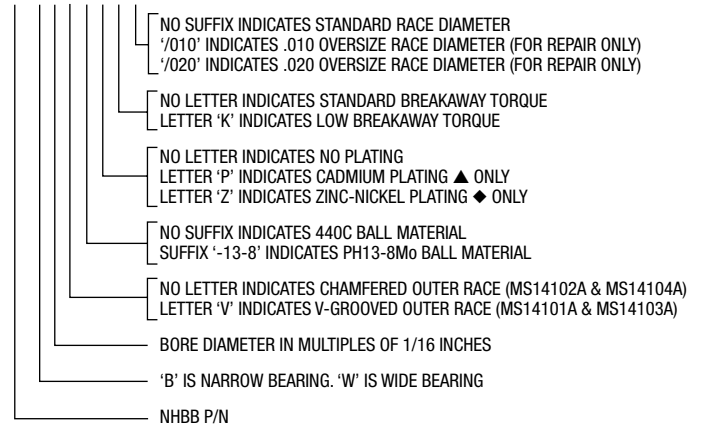

P/N SERIES	NHBB P/N	DESCRIPTION
MS14101A	MKB_V	Narrow Grooved
MS14102A	MKW	Wide Chamfered
MS14103A	MKW_V	Wide Grooved
MS14104A	MKB	Narrow Chamfered

▲ Cadmium plating per AMS-QQ-P-416, Type II, Class 2. For MS14102A & MS14104A, plate O.D. and O.D. chamfers. For MS14101A & MS14103A, plate O.D. and on the flats between the outside diameter grooves. Dimensions apply after plating.

◆ Zinc-nickel plating per AMS-2417, Type 2. For MS14102A & MS14104A, plate O.D. and O.D. chamfers. For MS14101A & MS14103A, plate O.D. and on the flats between the outside diameter grooves. Dimensions apply after plating.

Wide Series

PART NUMBER V-GROOVED*	MS DASH NO.	(B) BORE DIA.	(D) OUTSIDE DIA.	(W) BALL WIDTH	(T) RACE WIDTH	(O) SHOULDER DIA.	BALL DIA.	(E) PITCH DIA.	(P) GROOVE DEPTH	(Q°) MIS-ALIGNMENT DEGREE	LIMIT STATIC RADIAL LOAD LBS.	LIMIT STATIC AXIAL LOAD LBS.	DYNAMIC OSC. RADIAL LOAD LBS.	WEIGHT LBS.
MS14102A		+0.000	+0.000	+0.00	±.005	MIN.	REF.	+0.00	+0.00	REF.				REF.
MS14103A		-0.005	-0.005	-0.02				-0.08	-0.10					
MKW3V	-3	.1900	.6250	.437	.327	.300	.531	.563	.025	15°	2,500	1,770	4,900	.031
MKW4V	-4	.2500	.6250	.437	.327	.300	.531	.563	.025	15°	5,500	1,770	4,900	.031
MKW5V	-5	.3125	.6875	.437	.317	.360	.593	.625	.025	14°	9,400	1,640	6,050	.035
MKW6V	-6	.3750	.8125	.500	.406	.466	.687	.712	.035	8°	13,700	2,630	8,310	.060
MKW7V	-7	.4375	.9375	.562	.442	.537	.781	.837	.035	10°	20,700	3,650	11,750	.080
MKW7V52◆	-7A	.4375	.9062	.562	.442	.537	.781	.806	.035	10°	19,700	3,650	11,750	.080
MKW8V	-8	.5000	1.0000	.625	.505	.607	.875	.900	.035	9°	21,400	4,970	14,950	.100
MKW9V	-9	.5625	1.1250	.687	.536	.721	1.000	1.025	.035	10°	26,600	5,370	18,100	.135
MKW10V	-10	.6250	1.1875	.750	.567	.747	1.062	1.087	.035	12°	29,000	6,130	20,250	.160
MKW12V	-12	.7500	1.3750	.875	.630	.845	1.250	1.251	.055	13°	37,000	7,730	26,200	.240
MKW14V	-14	.8750	1.6250	.875	.755	.995	1.375	1.501	.055	6°	65,200	10,800	33,600	.350
MKW16V	-16	1.0000	2.1250	1.375	1.005	1.269	1.875	2.001	.055	12°	104,000	19,300	56,250	.970
MKW18V	-	1.1250	2.2500	1.437	1.067	1.338	1.968	2.128	.055	14°	142,570	19,640	57,000	1.000
MKW20V	-	1.2500	2.3750	1.500	1.130	1.460	2.093	2.253	.055	13°	159,200	21,970	63,680	1.120
MKW20-5V	-	1.2500	2.0000	1.093	.942	1.406	1.781	1.878	.055	6°	112,360	14,890	44,940	.564
MKW22V	-	1.3750	2.5625	1.687	1.223	1.535	2.281	2.440	.055	15°	190,000	25,970	76,000	1.390
MKW24V	-	1.5000	2.6875	1.687	1.223	1.693	2.390	2.567	.055	14°	199,000	25,970	79,640	1.480

\*For chamfered version, delete 'V' from part number.

◆ MKW7V52 is a V-groove type bearing only.

NO LOAD BREAKAWAY TORQUE

Bore Sizes	Standard (in.- lbs.)	'K' Type (in.- lbs.)
3 & 4	.25-5	0-0.5
5-12	.25-8	0-1.0
14 & 16	.25-12	0-2.0
18 & 20	.25-18	0-2.0
22 & 24	.25-24	0-2.0

RADIAL AND AXIAL PLAY

P/N Series MS14101A & MS14104A		
Bore Size	Max. Radial Play (in.)	Max. Axial Play (in.)
3K-12K	.0007	.0028
14K-16K	.0010	.0040
P/N Series MS14102A & MS14103A		
Bore Size	Max. Radial Play (in.)	Max. Axial Play (in.)
3K-12K	.0007	.0021
14K-16K	.0010	.0030

## Astro Division, Laconia, NH

Astro designs and manufactures highly specialized custom bearings, next-up assemblies, and machined parts requiring significant engineering expertise and specialty materials. Our stringent process controls and advanced planning system enable us to satisfy unique production requirements and provide improved delivery scheduling as part of our continuous improvement culture and commitment to customer satisfaction.

### PRODUCTS

- Rod ends
- Sphericals
- Link assemblies
- Bushings
- Loader slot bearings
- Custom-lined parts
- Bearings up to 22" O.D.
- Next-up assemblies & machined parts

### NMB, KARUIZAWA, JAPAN\*

- Rod ends
- Sphericals
- Spherical roller bearings
- Self-aligning roller bearings
- Next-up assemblies & machined parts

### QUALITY CERTIFICATIONS

- ISO 9001:2008
- AS9100, Rev C
- Boeing D6-82479
- FAA FAR 21.303

### NADCAP

- AC7102 – Heat-treating
- AC7108 – Chemical processing
- AC7114 – Nondestructive testing
- AC7118 – Composites/bonding

### ENVIRONMENTAL MANAGEMENT CERTIFICATION

- ISO 14001:2004

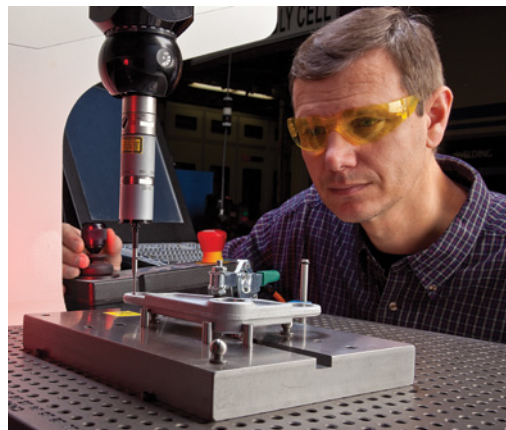

\*Astro is the North American sales representative for products manufactured by NMB's facility in Karuizawa, Japan, giving customers access to a global supply of high quality commercial aerospace parts.

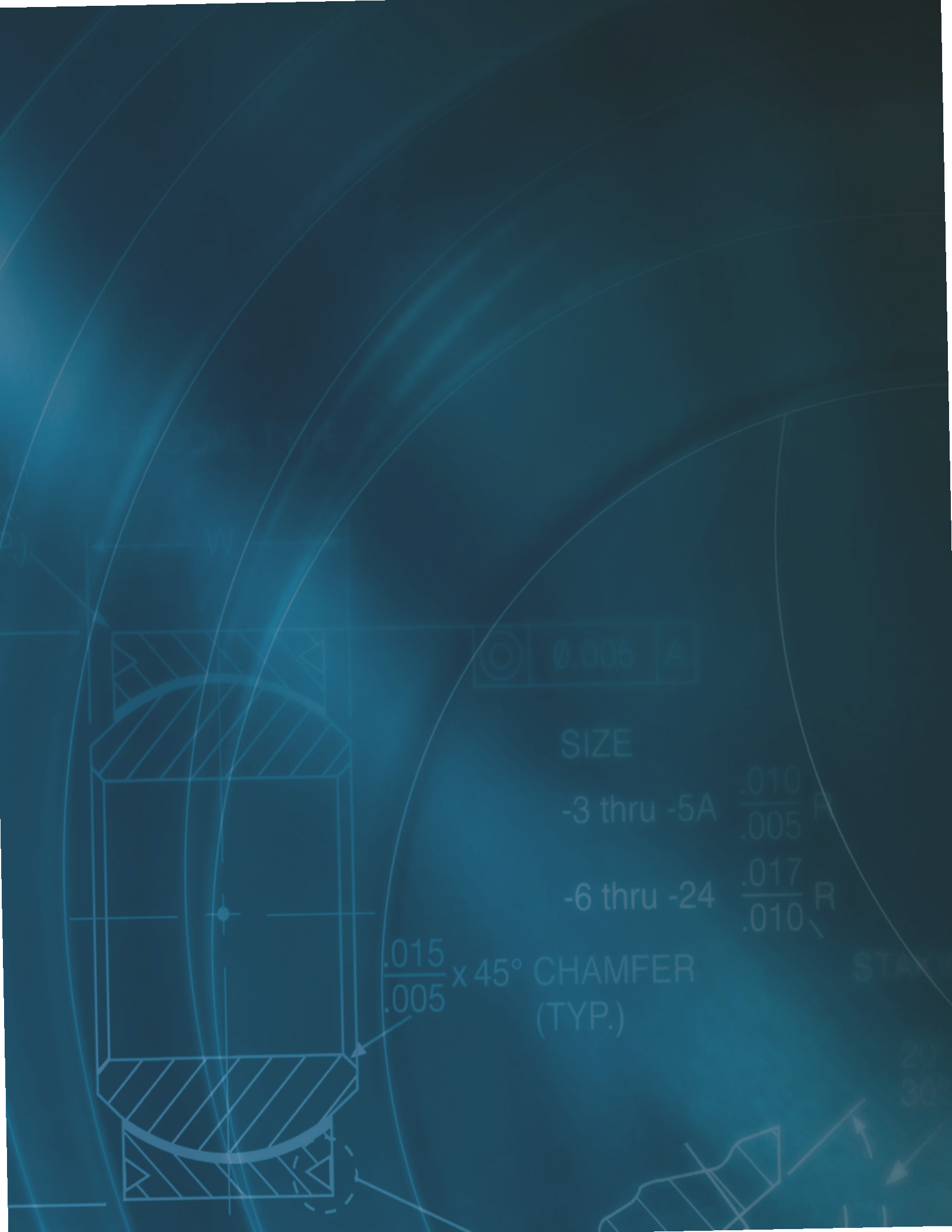

⊙  $\varnothing.005$  A

SIZE

-3 thru -5A	$\frac{.010}{.005}$	F
-6 thru -24	$\frac{.017}{.010}$	R

$\frac{.015}{.005}$  x 45° CHAMFER (TYP.)

STAG

20  
30



New Hampshire Ball Bearings, Inc.

————— ***A Minebea Company*** —————

**Astro Division**

155 Lexington Drive  
Laconia, NH 03246

tel: 603.524.0004 fax: 603.524.9025

**Other NHBB Divisions**

**Precision Division and  
Corporate Headquarters**

9700 Independence Avenue  
Chatsworth, CA 91311

tel: 818.993.4100 fax: 818.407.5020

**HiTech Division**

175 Jaffrey Road  
Peterborough, NH 03458

tel: 603.924.4100 fax: 603.924.4419

**myonic USA**

9700 Independence Avenue  
Chatsworth, CA 91311

tel: 818.701.4833 fax: 818.407.5020

**NHBB Europe**

Siemensstrasse 30  
63225 Langen  
Germany

tel: (49) 6103.913.341 fax: (49) 6103.913.342

**[nhbb.com](http://nhbb.com)**